

CGS-347XL

End Wheel for Track, Galvanized

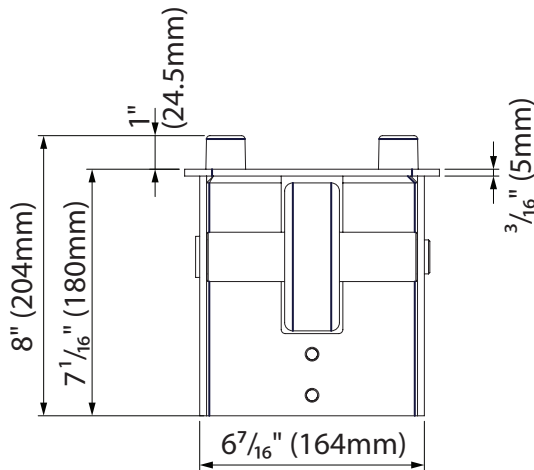
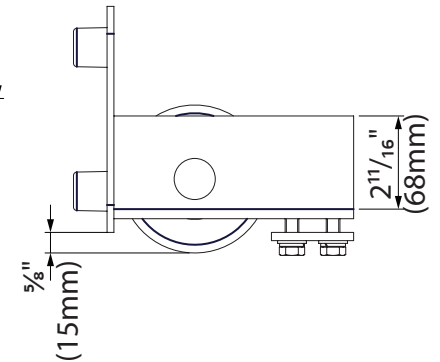
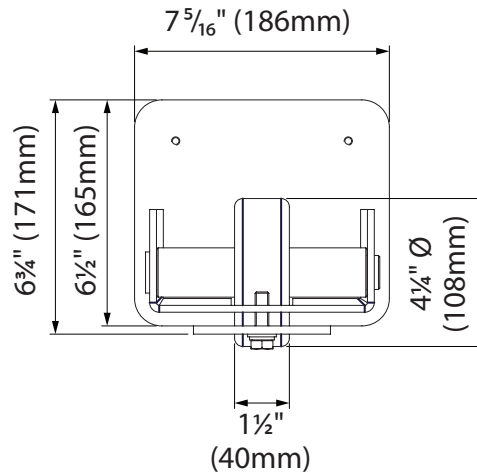

USE: Terminal with wheel for monorail.

FIXING: Tighten the fixing plate below the edges of the monorail.

RECYCLING: Disposal as ferrous material in accordance with the current laws in the country of installation.

IMPORTANT: The manufacturer reserves the right to modify the characteristics of the product as required without notice. The manufacturer declines any liability for even partial modifications to the product, and the declared performance values are valid only if the installation procedures are carried out by qualified personnel.

MAINTENANCE FREQUENCY: This article does not require any type of maintenance. In case of product replacement, check its functionality.

TECHNICAL CHARACTERISTICS	
CGS-347XL	
WEIGHT OF PART	7,00 Kg
MATERIAL	Galvanised steel
COMBINED MONORAIL	CGS-345XL
COMBINED STRIKER PLATE	CGS-346XL

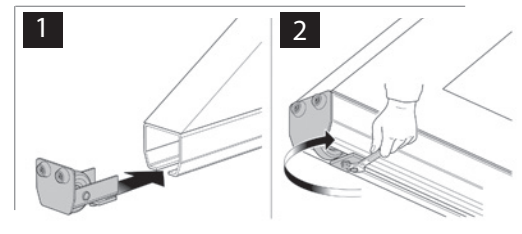
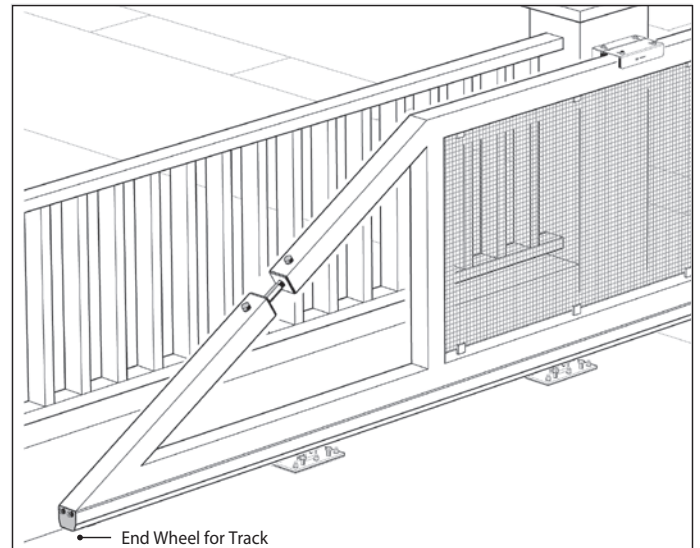

Illustrations not to scale and are for reference only. Imperial units shown are for reference only, use millimeters for most accurate sizes.

All pictures, technical drawings and related specifications belong to Fratelli Comunello Spa and they are defended by rules of copyright. All uses not expressly authorized will be legally prosecuted. Product specifications are subject to change without notice.