

CGS-496-20K

Bottom End Cup, Galvanized

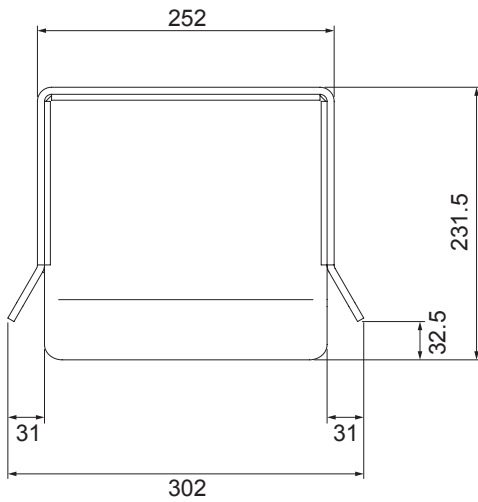
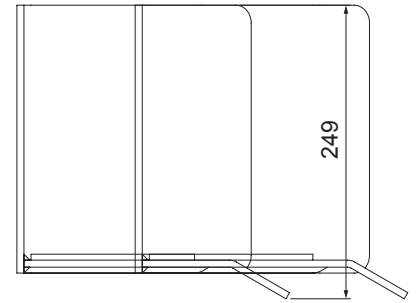
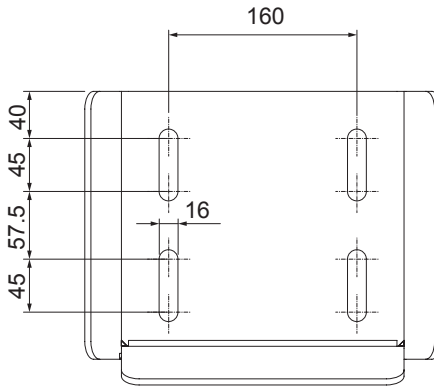

**ALL MEASUREMENTS
ARE IN MILLIMETERS**

USE: Striker for self-supporting gates.

TYPE: Lower striker for fixing.

FIXING: For fixing on post or for fixing on special bracket CG-15.

MATERIAL: Electrogalvanised steel.

RECYCLING: Disposal as ferrous material in accordance with the current laws in the country of installation.

IMPORTANT: The manufacturer reserves the right to modify the characteristics of the product as required without notice. The manufacturer declines any liability for even partial modifications to the product, and the declared performance values are valid only if the installation procedures are carried out by qualified personnel.

MAINTENANCE FREQUENCY: This article does not require any type of maintenance. Check its functionality and replace the product if necessary.

TECHNICAL CHARACTERISTICS	
	CGS-496-20K
WEIGHT OF PART	9,5 Kg
COMBINED MONORAIL	CGS-495-20K
TERMINAL WITH COMBINED WHEEL	CGS-497-20K

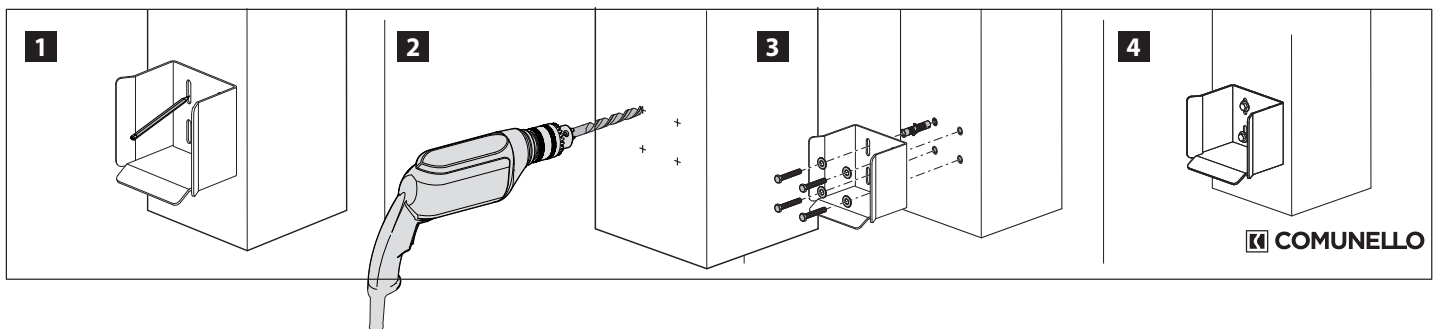

Illustrations not to scale and are for reference only. Imperial units shown are for reference only, use millimeters for most accurate sizes.

All pictures, technical drawings and related specifications belong to Fratelli Comunello Spa and they are defended by rules of copyright. All uses not expressly authorized will be legally prosecuted. Product specifications are subject to change without notice.