

# CGS-500.8 M

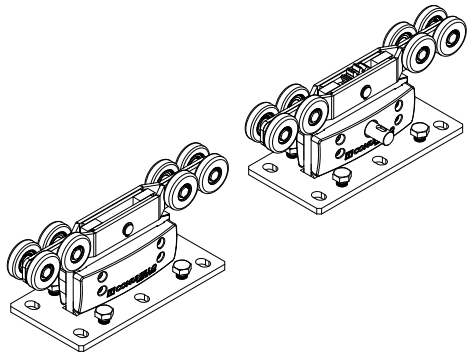

91300386 - 03/20 Rev. 01 UNI/EN ISO9001 - UNI/EN ISO14000

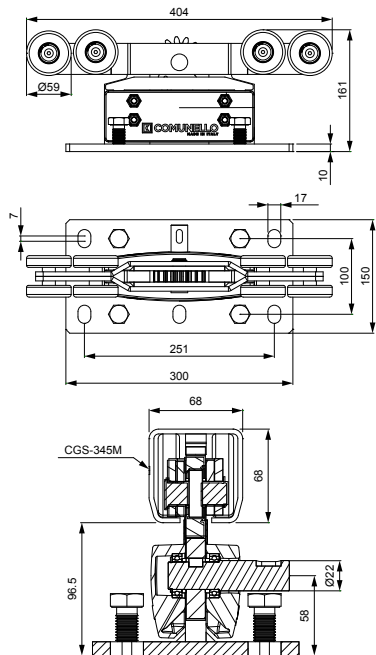

Art.		Code		
CGS-500.8 M	MINI	10131500 001	1	21,5

## EN

**USE:** Carriages with integrated transmission for cantilever gates. TYPE: 8 wheel Integrator Master & Slave carriages kit.

**FIXING:** Use 6 + 6 anchor bolts CG-348 M16 or appropriate anchors (both not supplied). For the dimensions of the concrete base, see table 1. The base allows height adjustment using the 4 M16 screws and the special counter-plate CG-05.

**MATERIAL:** Electrolytically Galvanized Steel and Painted Aluminum.

**RECYCLING:** Dispose of the main structure (wheels, plates and pins) as ferrous material and the side protections as aluminum, according to the laws of the country of installation.

**PARTS SUBJECT TO WEAR:** Bearings, wheels and gears.

**WARNINGS:** The manufacturer reserves the right to change the characteristics of the product according to their needs without prior notice. The manufacturer is not liable for even partial modifications of the product and the declared performances are valid only if the installation methods indicated in the instructions and performed by qualified personnel are followed.

TECHNICAL CHARACTERISTICS				
WEIGHT OF PART		21,5 Kg		
CAPACITY (maximum force on the carriage axis), IT IS NOT THE WEIGHT OF THE GATE		F1 max 1200 Kgf		
COMBINABLE COMPONENTS		CGS-345M		
PRIVATE HOME		BUSINESS		WAREHOUSE
2 YEAR*	2 YEAR *	1 YEAR *		CONDOMINIUM <20 UNITS
			6 MONTHS*	CONDOMINIUM > 20 UNITS
				6 MONTHS *
Check the functionality and integrity of carriages.				
Clean lower area of contact between wheels and rail				
Make sure the carriages are integral with the concrete base				
Grease the gears with the appropriate grease (FIG.4)				
Check gears and racks wear				
Check fastening of the locking screws of the rack to the monorail				
*The scheme refers to a normal workplace (not marine or particularly aggressive environments).				

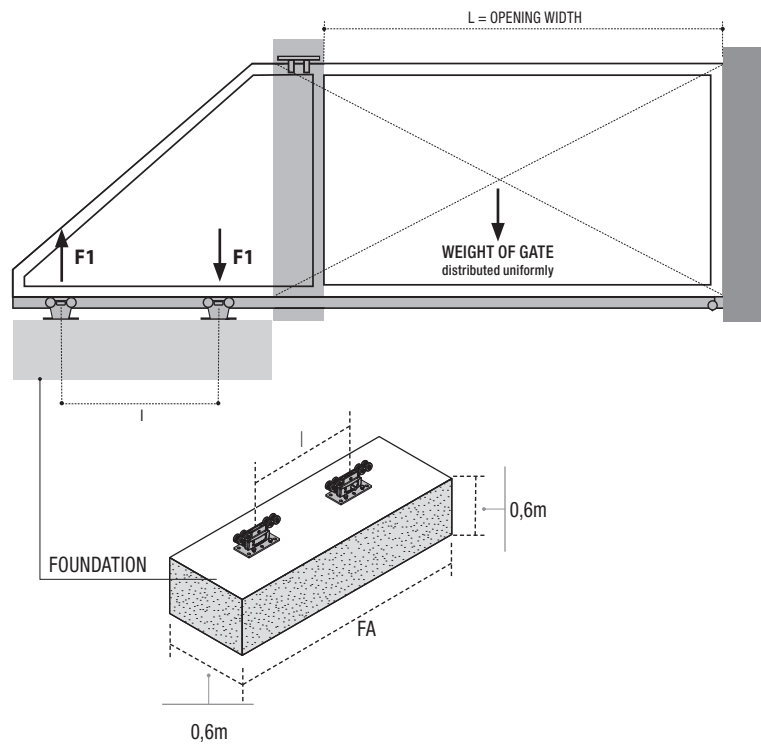

CG-05M  
CG-10  
CG-348 M16

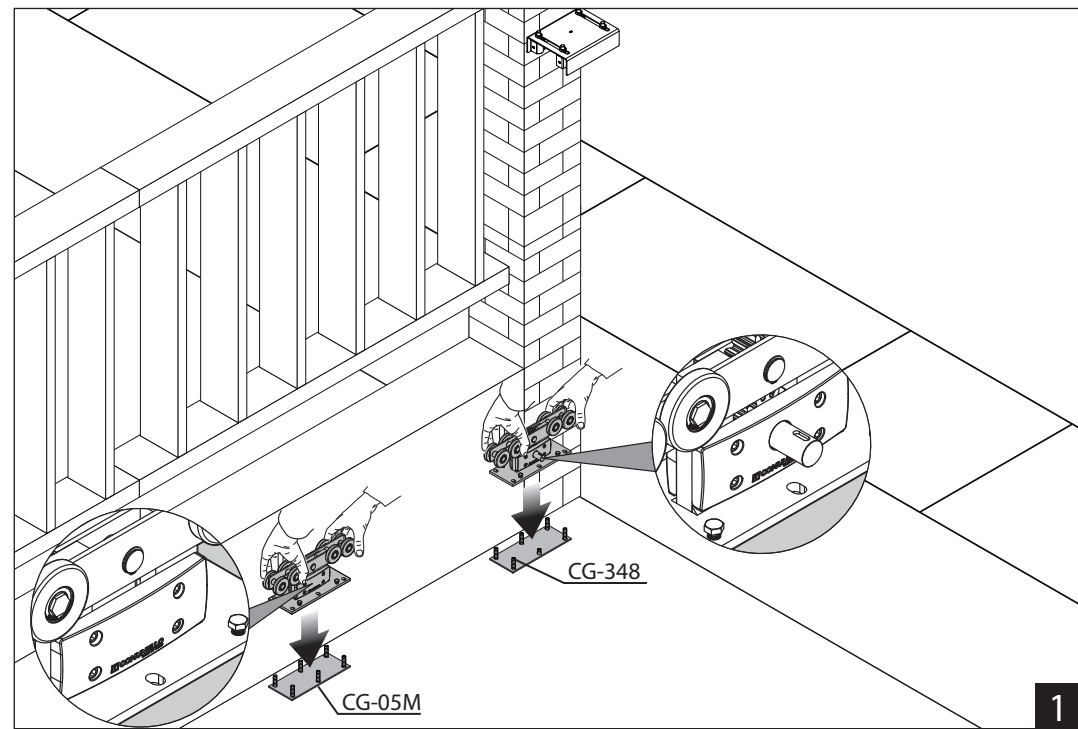

TAB.01

CSG - 500.8 M (F1max=1200 Kg)												
WEIGHT (Kg)	L=2 m		L=3 m		L=4 m		L=5 m		L=6 m		L=7 m	
	FA [m]	l [m]	FA [m]	l [m]	FA [m]	l [m]	FA [m]	l [m]	FA [m]	l [m]	FA [m]	l [m]
100	1.2	0.5	1.5	0.8	1.7	1.0	2.0	1.3	2.2	1.5	2.5	1.8
150	1.2	0.5	1.5	0.8	1.7	1.0	2.0	1.3	2.2	1.5	2.5	1.8
200	1.2	0.5	1.5	0.8	1.7	1.0	2.0	1.3	2.2	1.5	2.5	1.8
250	1.2	0.5	1.5	0.8	1.7	1.0	2.0	1.3	2.2	1.5	2.5	1.8
300	1.2	0.5	1.5	0.8	1.7	1.0	2.0	1.3	2.2	1.5	2.5	1.8
350	1.3	0.6	1.5	0.8	1.7	1.0	2.0	1.3	2.3	1.6	2.6	1.9
400	1.4	0.7	1.7	1.0	2.0	1.3	2.3	1.6	2.6	1.9	2.9	2.2
450	1.5	0.8	1.8	1.1	2.2	1.5	2.6	1.9	3.0	2.3	3.4	2.7
500	1.7	1.0	2.1	1.4	2.5	1.8	2.9	2.2	3.4	2.7	3.9	3.2

